



KT

Assembly tables



Assembly table for vertical and horizontal assembly. Stable steel construction. Important when switching from vertical to horizontal transportation and vice versa. Ideal for vertical and horizontal assembly. Pneumatic tilting. Table supporting surface with plastic slide bars. Roller support can be lowered pneumatically. 4-fold compressed air supply.



Supporting surfaces

Supporting surfaces with plastic slide bars

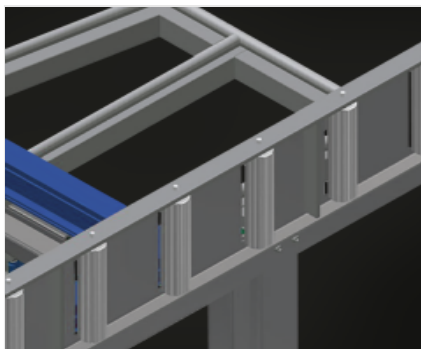

Roller support

Roller conveyor can be lowered pneumatically to allow unhindered working in horizontal position; in vertical position, trouble-free onward transport is possible

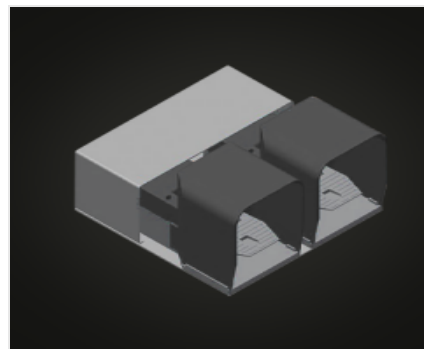

Foot switch

Control via foot valve. Pneumatic horizontal/vertical tilting



4-fold compressed air connection

4-fold compressed air connection for connecting compressed-air tools

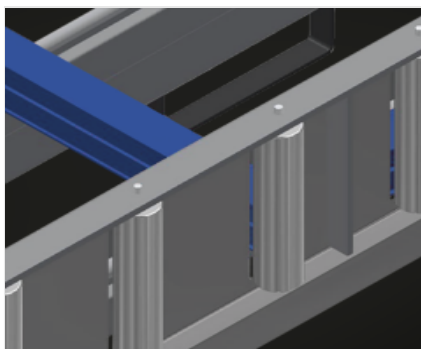

Profile protectors for support rollers (Optional)

Profile protectors for support rollers 200 mm (Alum./16 x and Alum./21 x). Roller conveyor with protective tubing over the rollers to protect the window element during infeed and outfeed

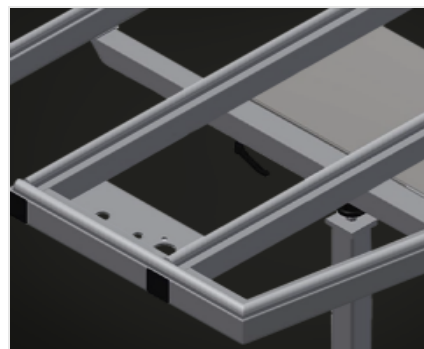

Pull-out profile support (Optional)

Pull-out table support at top for KT/KTH 3000 and KT/KTH 4000. The table support can be pulled out 500 mm at the top for high frames



Brush strip (Optional)

Supporting surfaces with brush strip

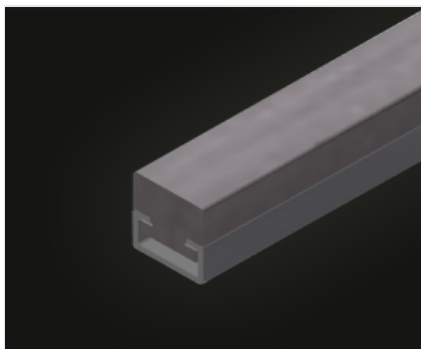

Felt strip (Optional)

Supporting surfaces with felt strip



Rubber strips (Optional)

Supporting surfaces with rubber-knob profile



Mobility unit (Optional)

Mobility unit for KT/KTH/MS/VE.
Mobility unit with flanged rollers and fixing brake

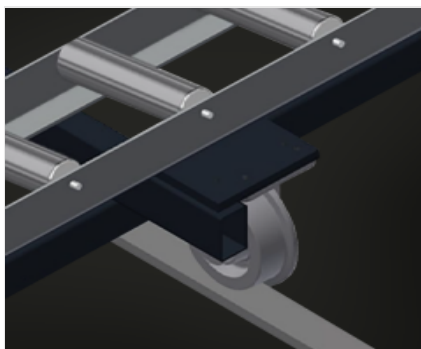

Rails (Optional)

Rails, 2.0 m, left and right



MODELS

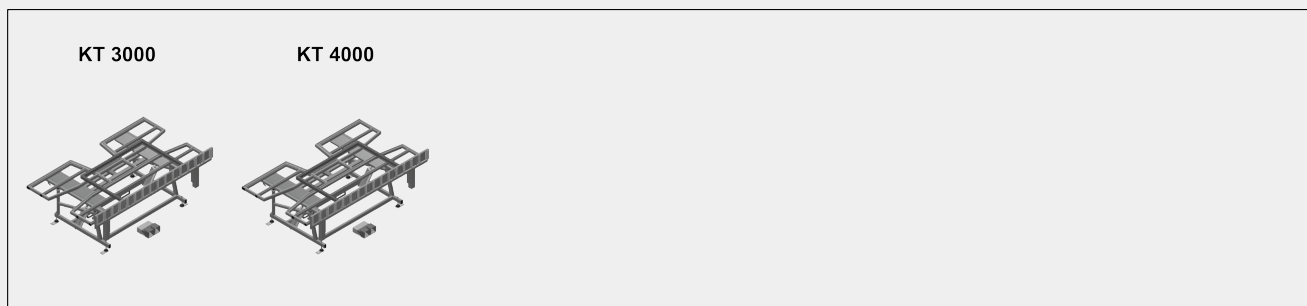

DIMENSION AND WEIGHT

KT 3000 / KT 4000

Length (mm)	3.000 / 4.000
Width (mm)	1.820
Vertical height (mm)	1.900
Roller conveyor width (mm)	200
Weight (kg)	330 / 380

SUPPORTING SURFACE

Pneumatic height adjustment (mm)	500
Pneumatic tilting	<input checked="" type="radio"/>
Extendable table support	<input type="radio"/>
Table brush strip supporting surface	<input type="radio"/>
Table felt profile strip supporting surface	<input type="radio"/>
Table rubber knob profile	<input type="radio"/>
Profile protectors for support rollers	<input type="radio"/>
Load capacity (kg)	200



CHARACTERISTICS

4-fold compressed air supply	<input checked="" type="radio"/>
Mobility unit	<input type="radio"/>
Rail 2,0 m left and right	<input type="radio"/>
Operating air pressure (bar)	7
Air consumption approx. (l/min)	35

Included ● Available ○