



VE

Inspection and glazing units



Inspection and glazing unit for glazing and final inspection in individual and serial assembly line production. Quick and precise assembly of windows, doors and elements. Stable steel construction. Easy operation by means of foot switch.

VE 3000 / VE 4000: Precision ensured through parallel clamping bar pressing technique. Height continuously adjustable. Two pressing bars which fold down and can be moved pneumatically and 4-fold compressed air supply.

VE 3000/60: Precision ensured through parallel clamping bar pressing technique with manually operated pressing bars. Pneumatic centring, storage area for tools and 4-fold compressed air supply.



**Back support
VE 3000 / VE 4000**

Rear back support with plastic slide bars



Roller support VE 3000

Lower roller conveyor with support roller, L = 200 mm

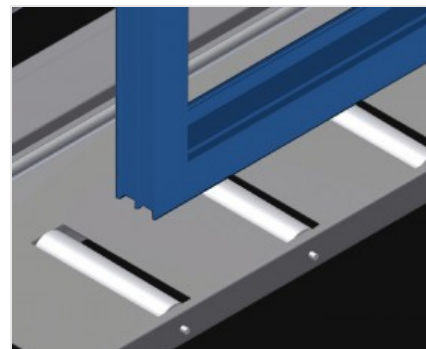

Roller support VE 4000

Lower roller conveyor with support roller, L = 200 mm



Foot switch VE 3000

All functions are controlled via foot valves



Foot switch VE 4000

All functions are controlled via foot valves

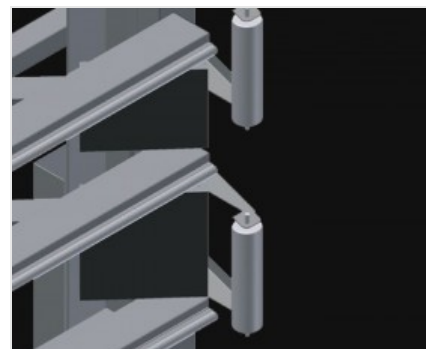

**Pressing bar
VE 3000 / VE 4000**

Simultaneous folding and moving of the pressing bars ensure a minimum of time is required for opening and closing the press. Allows free pass-through of the window



**Pressing bar
VE 3000/60**

Pneumatic centring. Precision ensured through parallel clamping bar pressing technique



**Back support
VE 3000/60**

Rear back support with plastic slide bars



**Roller support
VE 3000/60**

Lower roller conveyor with support roller, L = 120 mm



Foot switch VE 3000/60

All functions are controlled via foot valves



**4-fold compressed air
connection**

4-fold compressed air connection for connecting compressed-air tools



**Left lead-in rollers
VE 3000 / VE 4000
(Optional)**

Protective rollers for beginning or end of roller conveyor



**Right lead-in rollers
VE 3000 / VE 4000
(Optional)**

Protective rollers for beginning or end of roller conveyor

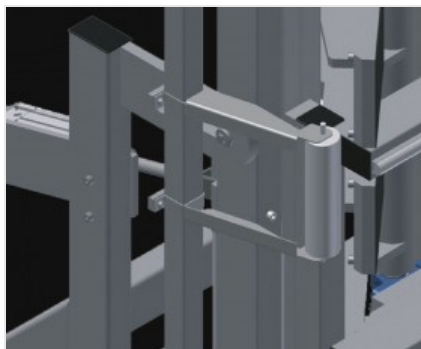

**Tilt adjustment of 0° - 8°
VE 3000 / VE 4000
(Optional)**

Pneumatic tilt adjustment of 0° - 8°



**Profile protectors
VE 3000 (Optional)**

Profile protectors for support rollers 200 mm. Support rollers covered with protective tubing



**Profile protectors
VE 4000 (Optional)**

Profile protectors for support rollers 200 mm. Support rollers covered with protective tubing

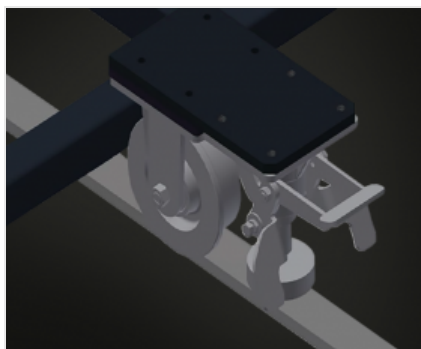

**Mobility unit
VE 3000 / VE 4000
(Optional)**

Mobility unit with flanged rollers and fixing brake

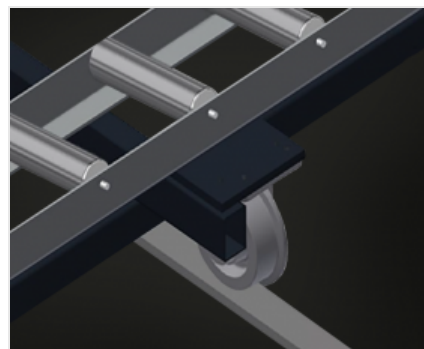

**Rails VE 3000 / VE 4000
(Optional)**

Rails, 2.0 m, left and right



**Height adjustment
VE 3000/60 (Optional)**

Height continuously adjustable, L =
500 mm



MODELS

DIMENSION AND WEIGHT

VE 3000 / VE 4000 / VE 3000/60

Length (mm)	4.410 / 5.440 / 3.050
Width (mm)	1.180 / 1.180 / 900
Height (mm)	2.600
Lower roller conveyor width (mm)	200 / 200 / 120
Weight (kg)	470 / 580 / 370

WORKPIECE LOCKING

VE 3000 / VE 4000 / VE 3000/60

Maximum clamping width (mm)	3.000 / 4.000 / 2.800
Minimum clamping width (mm)	400 / 390 / 390
Clamping bar height (mm)	2.300
Clamping bar width (mm)	120 / 200 / 100

VE 3000/60

Pneumatic centring	●
--------------------	---



Included ● Available ○

Voilàp S.p.A.
Via Archimede, 10
41019 - Limidi di Soliera (MO)
ITALY

Tel 059 895411
Fax: 059 859404
P.IVA e C.F. 02057270361
info@somecopvc.com
www.somecopvc.com

The right to make technical alterations is reserved.