



KS 101

Complementary machines



Precise notching saw for 90° V-cuts in plastic profiles. The machine has 2 vertical pneumatic clamping devices. The adjustment of the cutting depth in Y-axis is infinitely variable via handwheel. The pneumatic blade feed is infinitely variable and the return stroke is rapid. The machine is equipped as standard with a waste/chip container, blades and connection for a chip suction hose.



KS 101 / COMPLEMENTARY MACHINES

LAYOUT

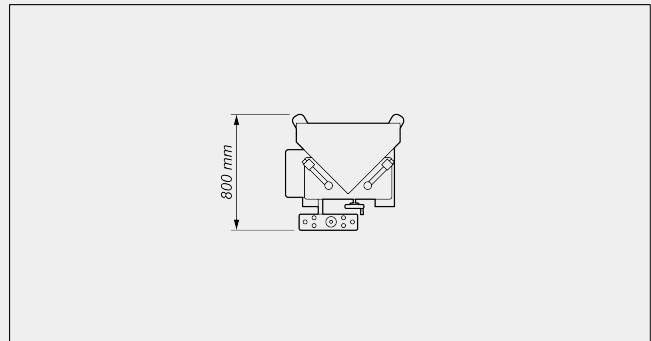
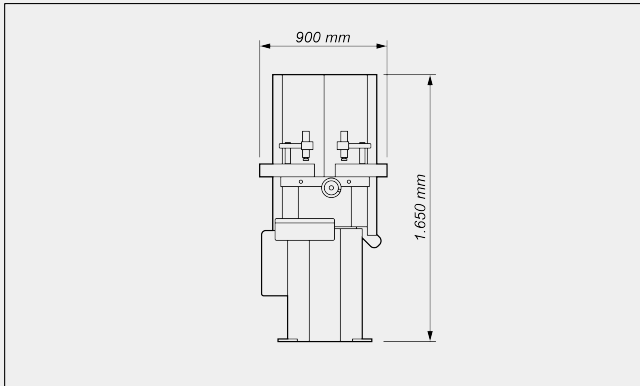

View from the above

The overall dimensions may vary depending on the product configuration.

WORK AREA

Maximum cutting depth (mm)	80
Maximum profile height (mm)	100
Minimum profile length for clamping (mm)	150
V-cut angle	90°

DIMENSION AND WEIGHT

Width (mm)	900
Depth (mm)	800
Weight (kg)	240
Height (mm)	1.650

MOTORS

Three-phase asynchronous motors	2
Power in S1 (kW)	2 x 0,9
Motor speed 50 Hz (r.p.m.)	2.800
Motor speed 60 Hz (r.p.m.)	3.400

Voilàp S.p.A.
Via Archimede, 10
41019 - Limidi di Soliera (MO)
ITALY

Tel 059 895411
Fax: 059 859404
P.IVA e C.F. 02057270361
info@somecopvc.com
www.somecopvc.com

The right to make technical alterations is reserved.



CUTTING DIAGRAM



TOOLS

Blade diameter (mm)	300
Blade bore (mm)	32
Blade speed - 60 Hz motor (r.p.m.)	3.400
Blade speed - 50 Hz motor (r.p.m.)	2.800

EQUIPMENT

Swarf box	●
Swarf exhauster connector	●
Carbide-tipped blade 80 teeth	●
Vertical clamping device	●

ELECTRICAL CONNECTION

Connected load (KW)	1,9
Maximum backup fuse 240V 60Hz (A)	10
Maximum backup fuse 400V 50Hz (A)	10

PNEUMATIC CONNECTION

Pressure (bar)	7
Hose connection	DN10
Compressed air consumption (7 bar) per working cycle (without spraying) (l)	20

Included ● Available ○

Voilàp S.p.A.
 Via Archimede, 10
 41019 - Limidi di Soliera (MO)
 ITALY

Tel 059 895411
 Fax: 059 859404
 P.IVA e C.F. 02057270361
 info@somecopvc.com
 www.somecopvc.com

The right to make technical alterations is reserved.