

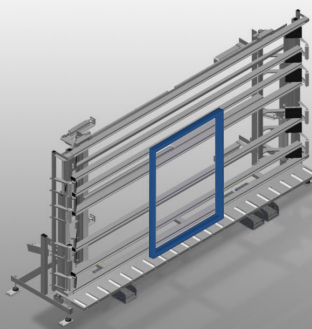

VE 4000

Inspection and glazing
units



Inspection and glazing unit for glazing and final inspection in individual and serial assembly line production. Quick and precise assembly of windows, doors and elements. Stable steel construction. Precision ensured through parallel clamping bar pressing technique. Height continuously adjustable. Easy operation by means of foot switch. Two pressing bars which fold down and can be moved pneumatically and 4-fold compressed air supply.

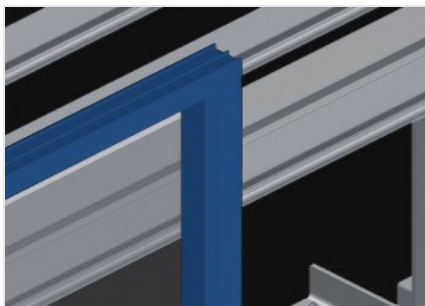

Back support

Rear back support with plastic slide bars

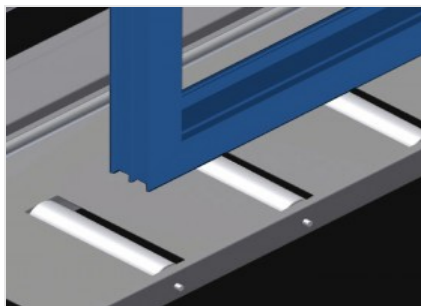

Roller support

Lower roller conveyor with support roller, L = 200 mm

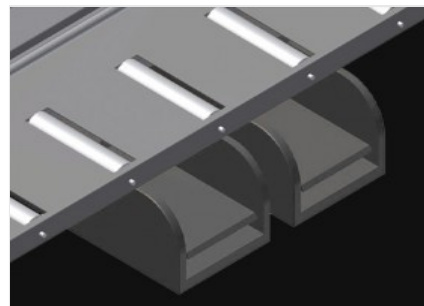

Foot switch

All functions are controlled via foot valves

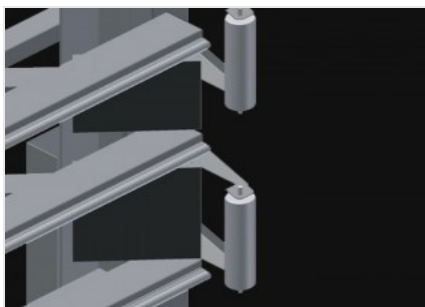

Pressing bar

Simultaneous folding and moving of the pressing bars ensure a minimum of time is required for opening and closing the press. Allows free pass-through of the window



Left lead-in rollers (Optional)

Protective rollers for beginning or end of roller conveyor



Right lead-in rollers (Optional)

Protective rollers for beginning or end of roller conveyor



Tilt adjustment of 0° - 8° (Optional)

Pneumatic tilt adjustment of 0° - 8°

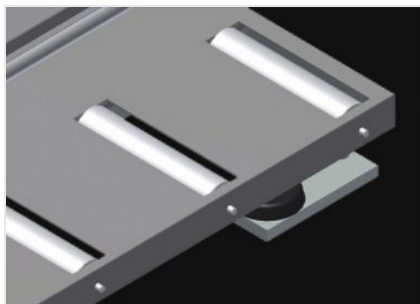

Profile protectors (Optional)

Profile protectors for support rollers 200 mm. Support rollers covered with protective tubing

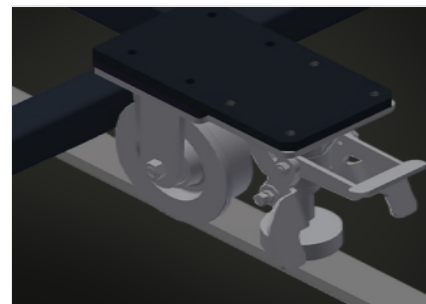

Mobility unit (Optional)

Mobility unit for KT/KTH/MS/VE.
Mobility unit with flanged rollers and fixing brake

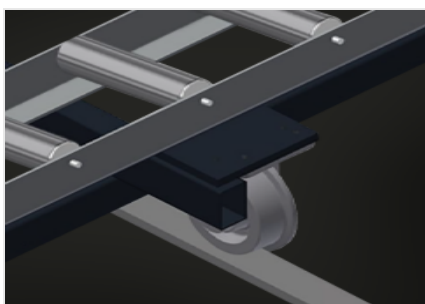

Rails (Optional)

Rails, 2.0 m, left and right



VE 4000 / INSPECTION AND GLAZING UNITS

DIMENSION AND WEIGHT

Length (mm)	5.440
Width (mm)	1.180
Height (mm)	2.600
Lower roller conveyor width (mm)	200
Weight (kg)	580

WORKPIECE LOCKING

Maximum clamping width (mm)	4.000
Minimum clamping width (mm)	390
Clamping bar height (mm)	2.300
Clamping bar width (mm)	200

CHARACTERISTICS

Load capacity (kg)	200
Adjustable height (mm)	500
Height continuously adjustable	<input checked="" type="radio"/>
Pneumatic tilt adjustment of 0° - 8°	<input type="radio"/>
4-fold compressed air supply	<input checked="" type="radio"/>
Lead-in rollers right, complete L= 2052 mm	<input type="radio"/>
Lead-in rollers left, complete L= 2052 mm	<input type="radio"/>
Profile protectors for L= 200 mm	<input type="radio"/>
Mobility unit	<input type="radio"/>
Rail 2,0 m left and right	<input type="radio"/>
Operating air pressure (bar)	7
Air consumption approx. (l/min)	35

Included ● Available ○

Voilàp S.p.A.
 Via Archimede, 10
 41019 - Limidi di Soliera (MO)
 ITALY

Tel 059 895411
 Fax: 059 859404
 P.IVA e C.F. 02057270361
 info@somecopvc.com
 www.somecopvc.com

The right to make technical alterations is reserved.